

CESeasy

Motor cylinder



Mechanical cylinder

Outside (S) / Inside (K)

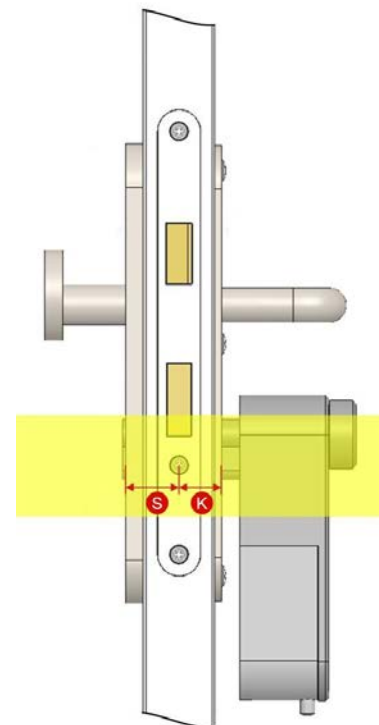
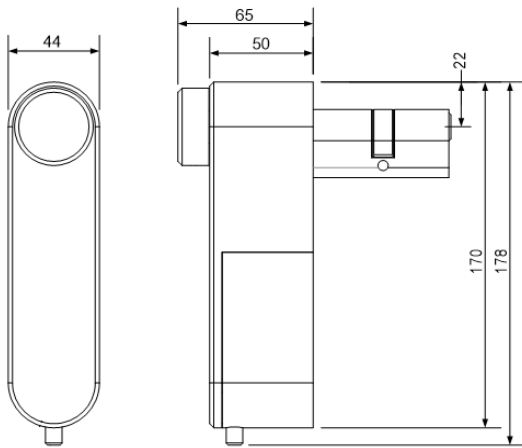

CESeasy - Motor cylinder

Technical data

CESeasy motor cylinder	
Article number	Motorised cylinder: 347100V Complete package: EASY-xxx (xxx = profile range, e.g. WD5): Motor cylinder with mounted locking cylinder, 1 mechanical key, 5 digital keys, 1 remote control, 1 "lock management" function (5 years), door contact and connecting cable for door contact
Material	ABS, lacquered / anodized aluminium
Locking cylinder	Each state-of-the-art CES locking system, incl. 1 key
Cylinder profile	Euro profile (PZ); optionally Swiss round profile (22mm)
Power supply	
Batteries	6 x AA alkaline batteries
Power input	12 VDC / 2.5 A / stabilised
Optional power supply unit	347130V
Inputs and outputs	
Sensor input	Input for an optional door contact (347129V). A special cable is required (347110V). Set containing a door contact and a cable: 347128V Max. cable length: 30 cm
Further inputs and outputs	Available via the CESeasy communication module
RF-Transceiver	
RF-Transceiver	868 MHz, for remote controls and the communication module
Bluetooth® Low Energy transc.	2.4 GHz, to communicate with mobile phones
Encryption	AES128
Memory / capacity	
Number of digital keys	600 access group (1 access group = max. 65,000 employee keys, or 1 digital key, or 1 remote control)
Encryption	AES128
Service life	
Service life	Min. 200.000 operations (at 20°C), in accordance with SKG
Battery service life	Approx. 7,500 operations (2 turns, latch and deadbolt, 1 Nm, at 20°C) in one year
Environment	
Device environment	The device side equipped with motor is suitable for indoor use only
Operating temperature	0 ... + 50°C
Humidity during operation	5 ... 90%, non-condensing
Unsuitable climates	Do not use in corrosive environments (chlorine, ammonia, lime water)
Tests and certificates	
Safety class	SKG***
CE label	NEN EN 300330-02, NEN EN 301489-03
Control and operation	
Mobile phone	Compatible Apple device (Bluetooth® Low Energy and iOS 9.2 or higher) Compatible* Android device (Bluetooth® Low Energy and Android 4.4 or higher)

* Due to the vast number of different Android phones and versions, testing the compatibility of a particular Android device is recommended.